

# Application Supplement For Vacant, Or Partially Vacant Buildings And Those Under Repair Or Reconstruction

## PART A — FOR ALL APPLICATIONS

Application or Policy Number: \_\_\_\_\_

Insured: \_\_\_\_\_

Producer: \_\_\_\_\_

Location of Property: \_\_\_\_\_

Building Type (Dwelling, Apartment House, Mercantile, Etc.): \_\_\_\_\_

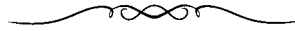

## PART B — CERTIFICATE FOR VACANT OR UNOCCUPIED BUILDINGS (NOT UNDER REPAIR OR RECONSTRUCTION)

The undersigned, who is applying to the NEW YORK PROPERTY INSURANCE UNDERWRITING ASSOCIATION for building coverage on premises located as described above, hereby certifies that the building is presently vacant or unoccupied and that all utilities (electricity, gas, heat and water) have been shut off outside the building and that the premises are and will continue to be securely protected against entry by unauthorized persons in accordance with the standards of the United States Department of Housing and Urban Development as specified below or by protective devices, systems, or equipment used in securing buildings against entry by unauthorized persons which are found by the NEW YORK PROPERTY INSURANCE UNDERWRITING ASSOCIATION to be equivalent; the undersigned recognizes that any binder or coverage issued or to be issued by the NEW YORK PROPERTY INSURANCE UNDERWRITING ASSOCIATION will be issued in reliance upon the foregoing certification and will contain the "Warranty" set forth in Section XI Subsection 5 of the Plan of Operation of the ASSOCIATION as set forth herein.

Insured: \_\_\_\_\_ Dated: \_\_\_\_\_

By: \_\_\_\_\_

"Warranted" — That the named insured shall maintain the insured building secure against entry by unauthorized persons in accordance with the standards of the U.S. Department of Housing and Urban Development or by protective devices, systems or equipment used in securing buildings against entry by unauthorized persons which are found by NYPIUA to be equivalent and shall certify in writing to the Association on the form supplied by the Association within ten (10) days after the first day of each month during the term of this policy that the building has been inspected within ten (10) days prior to the date of said certification and found to be secure as prescribed therein. Failure to so certify or any false certification will immediately suspend and render inoperative any insurance afforded by this policy.

### DOOR SECURITY

1. Fabricate from 3/4" exterior plywood.
2. Fit to entry door jamb. Leave 1/8" maximum clearance at all edges.
3. Use 3 strap hinges to heavy gauge case hardened steel. Place hinge on outside (for maximum swing) and secure so that all exposed carriage bolt heads cannot be removed.
4. This installation should be non-interfering with the property's door or lockbox and should open and close freely from any obstructions.

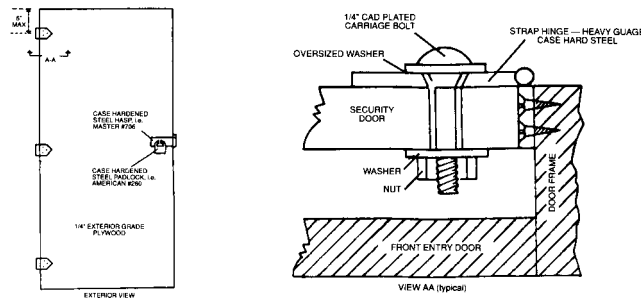

### WINDOW SECURITY

1. 3/8" or 1/2" Carriage Bolt mated with nut and 2-2" flat washers. Bolt and mating hardware may be galvanized or cad plated. Bolts to be tightened to maximum extent without disturbing wood materials.
2. 5/8" plywood attached to 2" x 4" with 10d clinched nailing.
3. Plywood to be painted aluminum or grey or grey on exterior surface and edges.
4. Must be exterior grade plywood.
5. Horizontal bars shall be placed sufficiently apart to accommodate opened double sash between bars.
6. Plywood seals are to be installed securely within the window opening and resting on window sill. If installation within the window framing is impractical, then plywood shall be installed with a minimum of 6 inch overlap on exterior walls on top and sides.

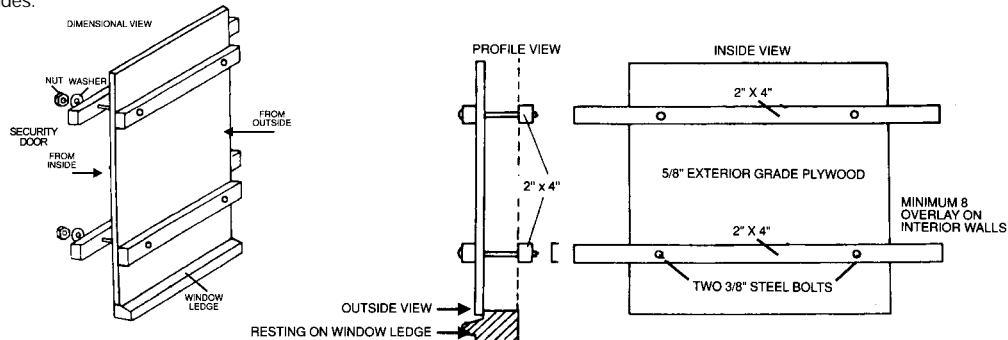

**PART C — CERTIFICATE AND WARRANTY FOR BUILDING UNDER REPAIR OR RECONSTRUCTION**

**IMPORTANT NOTICE**

**NEW YORK PROPERTY INSURANCE UNDERWRITING ASSOCIATION** will insure vacant buildings undergoing repair or reconstruction when work to accomplish these improvements is being done on a regular basis. Failure to perform work for any consecutive 60 day period of time within the policy term will be conclusive evidence that the premises are not under repair or reconstruction. For the purpose of this certification in order to be in compliance with the warranty below, the following are examples of activities that do not constitute work to accomplish improvements or constitute repair or renovation:

- Application for financing
- Application for permits
- Securing of the premises
- Preparation or completion of blueprints, architectural drawings, etc.
- Submission or approval of applications to any governmental authority
- Purchase of materials or hiring of labor
- Entering into contracts or other agreements to repair or reconstruct the premises
- Work that does not directly physically improve the premises
- Marketing
- Obtaining of financing
- Obtaining of permits
- Cleaning or removal of debris

Work to accomplish the improvements must continue on a regular basis unless written permission is received from the association to suspend work.

In the event that work on a regular basis ceases, the premises, upon application and acceptance by the association, may be insured as a vacant building. Please refer to the outline of procedure.

**SECURITY REQUIREMENTS FOR BUILDINGS UNDERGOING REPAIR OR RECONSTRUCTION**

When workers are absent, all accessible openings must be secured in such a fashion as to bar entry by unauthorized individuals. Acceptable methods for securing windows include cinder block, plywood fastened to frames, metal roll down gates or other methods used to secure a building considered by NEW YORK PROPERTY INSURANCE UNDERWRITING ASSOCIATION to be equivalent. Roll down gates, solid wood or metal doors without window openings are required for all accessible doorways.

**ANSWER ALL QUESTIONS:**

1. When will repair or reconstruction work begin? \_\_\_\_\_

When will work be completed? \_\_\_\_\_

2. Describe the nature and extent of work planned: \_\_\_\_\_

\_\_\_\_\_

3. Who will do the work?  Professional building or contractor  Do-it-yourself  Combination

Name and address of professional: \_\_\_\_\_

\_\_\_\_\_

Have contracts with professional been signed? (If yes, attach copies)  Yes  No

4. Have all necessary permits been obtained? (If yes, attach copies)  Yes  No

5. Have you obtained any necessary financing?  Yes  No

If yes, source of financing: \_\_\_\_\_

**WARRANTY:** It is warranted that improvements will be made to the premises on a regular basis and that when workers are absent, all accessible openings will be secured in accordance with association requirements.

Insured: \_\_\_\_\_

Dated: \_\_\_\_\_

By: \_\_\_\_\_



**PART D — QUESTIONNAIRE FOR PARTIALLY OCCUPIED BUILDINGS**

1. Identify vacant areas of the building:      How many in building?      How many vacant?      Percentage of area?

Type — Apartments \_\_\_\_\_

Stores \_\_\_\_\_

Commercial areas \_\_\_\_\_

Manufacturing areas \_\_\_\_\_

Other \_\_\_\_\_

2. Are all vacant areas in rentable condition?  Yes  No

If no, describe condition of areas not in rentable condition: \_\_\_\_\_

\_\_\_\_\_

3. Are any vacant areas on street level?  Yes  No

4. How are vacant areas secured? \_\_\_\_\_

\_\_\_\_\_

5. When is it anticipated that vacant areas will be occupied? \_\_\_\_\_

Insured: \_\_\_\_\_

Date: \_\_\_\_\_

By: \_\_\_\_\_